

## XPort™ Data Sheet

### General Description

The XPort™ is the most compact, integrated solution available to web-enable any device with a serial interface. By simply adding XPort™ to a product design, device manufacturers cut their design cycle by as much as 80% and are able to offer Ethernet connectivity in record time.



The XPort offers the highest level of integration available in a device server. Within a compact RJ45 package is a DSTni-EX 186 controller, memory, 10/100 Ethernet transceiver, high-speed serial port, status/diagnostic LEDs, and 3 programmable I/O pins. In the space that is normally consumed by a connector, the XPort provides a complete networking interface.

To enable access to a local network or the Internet, the XPort integrates a fully developed TCP/IP network stack and OS. The XPort also includes an embedded web server used to remotely configure, monitor, or troubleshoot the attached device.

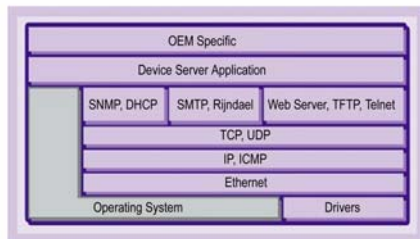
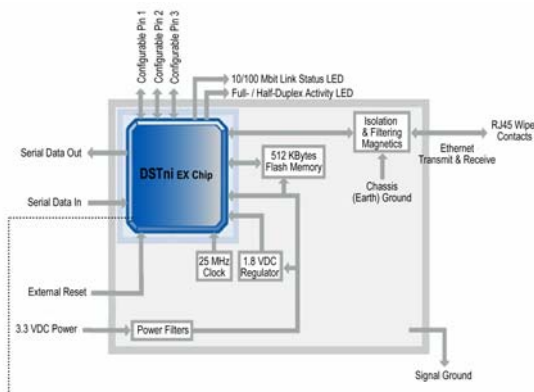

Where there's a need for custom user interfaces and a desire to use common and familiar tools, the XPort can serve web pages to a web browser. The XPort becomes a conduit between you and your device over the network or Internet.

The Windows™-based configuration software, DeviceInstaller, simplifies installation and setup. The XPort can also be set up locally through its serial port, or remotely over a network using Telnet or a web browser. Flash memory provides for maintenance-free nonvolatile storage of web pages, and allows future system software upgrades.

Using our highly integrated hardware and software platform, you will add profit to your bottom line by significantly reducing product development time, risk, and cost.

### Key Features

- The only complete, integrated solution in an RJ45 form factor
- Complete integrated solution
- Embedded web server
- 10/100Mbit Ethernet – Auto-Sensing
- Stable, field proven TCP/IP protocol suite and web-based application framework
- Easy configuration through a web interface
- Easy customization of HTML web pages and configuration screens
- Interactive web pages through the use of Java applets
- E-mail
- 128-, 192-, or 256-bit AES Rijndael encryption (Optional)
- EMI tested and compliant
- Extended operating temperature:
  - 40 to +85° C normal mode
  - 40 to +75° C high-performance mode
- High-performance processor (12 MIPS at 48 MHz, 22 MIPS at 88 MHz)
- Network overhead handled by XPort
- Password protection
- Upgrade XPort's firmware over the network
- 3.3V power
- Serial-to-10/100 Ethernet conversion
- 921,600 baud serial speed

## Hardware & Software Description

The XPort is a complete solution (hardware and software) for web-enabling your edge devices. Packed into an RJ45 connector smaller than your thumb, this powerful device server comes with a 10BASE-T/100BASE-TX Ethernet connection, a reliable and proven operating system stored in flash memory, an embedded web server, a full TCP/IP protocol stack, and standards-based (AES) encryption.

The XPort software runs on a DSTni-EX controller which has 256 KB of SRAM, 16 KB of boot ROM, and a MAC with integrated 10/100BASE-TX PHY. The XPort communicates to the edge device through a 3.3V serial interface and three general-purpose programmable I/O pins. 512 KB of flash memory is included for storing firmware and web pages. The XPort runs on 3.3V, and has a built-in voltage supervisory circuit that will trigger a reset if the supply voltage drops to unreliable levels (2.7V). A built-in 1.8V regulator drives the processing core of the EX controller.

An RJ45 Ethernet cable connects directly into an XPort. Ethernet magnetics, status LEDs, and shielding are built in. The XPort was designed to meet class B emissions levels, which makes the electromechanical integration very simple.

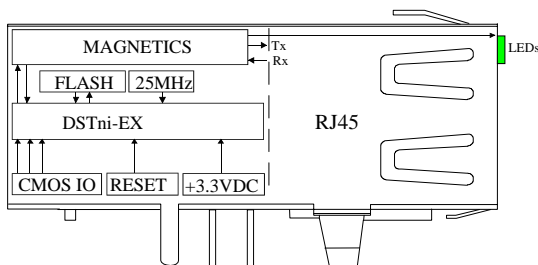

### PCB Interface

The 8-pin PCB interface consists of 3.3V CMOS Serial In/Out, 3 Flow Control/Handshake/PIO pins, reset input, +3.3V power, and signal ground. All pins are 5V tolerant.

Table 1 - PCB Interface Signals

Signal Name	Pin	Function
GND	1	Circuit Ground
Vcc	2	+3.3V Power In
Reset (In)	3	External Reset In
Data OUT	4	Serial Data Out
Data IN	5	Serial Data In
CP1	6	CP1 can be configured as follows: <ul style="list-style-type: none"> <li><b>Flow control:</b> RTS (Request to Send) <b>output</b> driven by DSTni's built-in UART for connection to CTS of attached device.</li> <li><b>Programmable input/output:</b> CP1 can be driven or read through software control, independent of serial port activity.</li> </ul>
CP2	7	CP2 can be configured as follows: <ul style="list-style-type: none"> <li><b>Modem control:</b> DTR (Data Terminal Ready) <b>output</b> driven by DSTni's built-in UART for connection to DCD of attached device.</li> <li><b>Programmable input/output:</b> CP2 can be driven or read through software control, independent of serial port activity.</li> </ul>
CP3	8	CP3 can be configured as follows: <ul style="list-style-type: none"> <li><b>Flow control:</b> CTS (Clear to Send) <b>input</b> read by DSTni's built-in UART for connection to RTS of attached device.</li> <li><b>Modem control:</b> DCD (Data Carrier Detect) <b>input</b> read by DSTni's built-in UART for connection to DTR of attached device.</li> <li><b>Programmable input/output:</b> CP3 can be driven or read through software control, independent of serial port activity.</li> </ul>

### Ethernet Interface

The 10/100 Ethernet magnetics, network status LEDs, and RJ45 connector are integrated into the XPort.

Table 2 - Ethernet Interface Signals

Signal Name	DIR	Contact	Primary Function
TX+	Out	1	Transmit Data +
TX-	Out	2	Transmit Data -
RX+	In	3	Receive Data +
RX-	In	6	Receive Data -
Not Used		4	Terminated
Not Used		5	Terminated
Not Used		7	Terminated
Not Used		8	Terminated
SHIELD			Chassis Ground

### Protocol Support

The XPort uses Internet Protocol (IP) for network communications and Transmission Control Protocol (TCP) to assure that no data is lost or duplicated, and that everything sent arrives correctly at the target.

Other supported protocols are listed below:

- ARP, UDP, TCP, ICMP, Telnet, TFTP, AutoIP, DHCP, HTTP, and SNMP for network communications.
- TCP, UDP, and Telnet for connections to the serial port.
- TFTP for firmware updates.
- IP for addressing, routing, and data block handling over the network.
- User Datagram Protocol (UDP) for typical datagram applications in which devices interact with other devices without maintaining a point-to-point connection.

\* For a complete discussion of protocol support, see the XPort user manual.

### LEDs

The device contains two bi-color LEDs built into the front of the XPort connector. (See dimension drawing for location.)

Link LED (Left Side)		Activity LED (Right Side)	
Color	Meaning	Color	Meaning
Off	No Link	Off	No Activity
Amber	10 Mbps	Amber	Half-Duplex
Green	100 Mbps	Green	Full-Duplex

### Recommended PC Board Layout

The hole pattern and mounting dimensions for the XPort are shown in the following drawing:

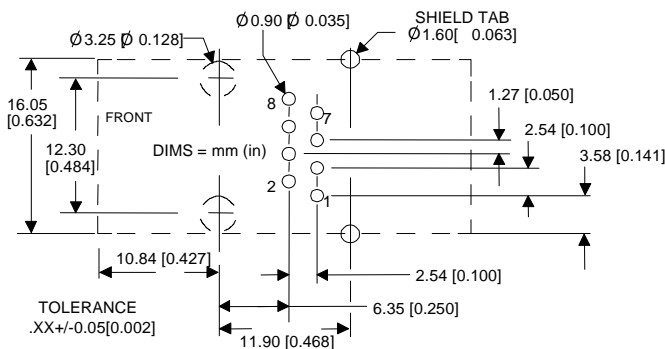

For proper heat dissipation, the PCB should have approximately 1 square inch of copper attached to the shield tabs. The shield tabs are an important source of heat sinking for the device.

### Dimensions

The XPort dimensions are shown in the following drawings:

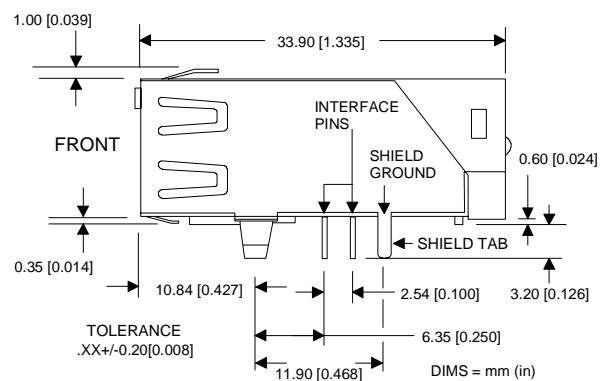
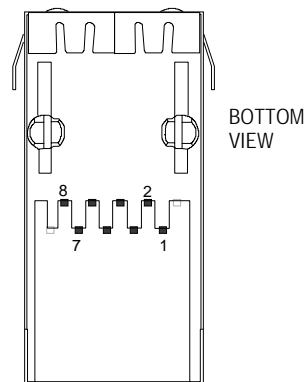
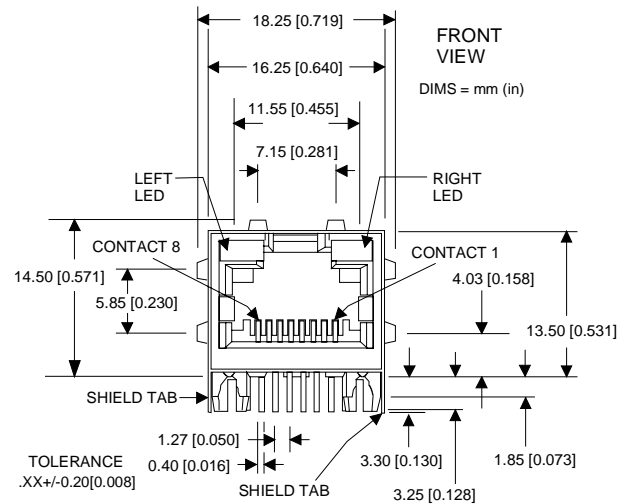

Note: PADS and PROTEL design files are included with the XPort development kit.

## XPort Technical Data

Category	Description
CPU, Memory	Lantronix DSTni-EX 186 CPU, 256 KB zero wait state SRAM 512 KB Flash, 16 KB Boot ROM
Firmware	Upgradeable via TFTP and serial port
Reset Circuit	Internal 200ms power-up reset pulse. Power-drop reset triggered at 2.6V. External reset input causes an internal 200ms reset.
Serial Interface	CMOS (Asynchronous) 3.3V-level signals Rate is software selectable (300 bps to 921600 bps)
Serial Line Formats	7 or 8 data bits, 1-2 Stop bits, Parity: odd, even, none
Modem Control	DTR/DCD, CTS, RTS
Flow Control	XON/XOFF (software), CTS/RTS (hardware), none
Programmable I/O	3 PIO pins (software selectable) sink or source 4mA max.
Network Interface	RJ45 Ethernet 10BASE-T or 100BASE-TX (auto-sensing)
Compatibility	Ethernet: Version 2.0/IEEE 802.3
Protocols Supported	ARP, UDP/IP, TCP/IP, Telnet, ICMP, SNMP, DHCP, BOOTP, TFTP, Auto IP, and HTTP
LEDs	10BASE-T & 100BASE-TX Link Activity, Full/half duplex. Software generated status & diagnostic signals can optionally drive external LEDs through CP1 & CP3 (see Int. Guide).
Management	Internal web server, SNMP, Serial login, Telnet login
Security	Password protection, locking features, optional Rijndael 128-, 192-, or 256-bit encryption
Internal Web Server	Serves web pages Storage capacity: 384 KB
Weight	9.6 grams (0.34 oz)
Material	Metal shell, thermoplastic case
Temperature	Operating range: -40°C to +85°C (-40°F to 185°F) normal mode -40°C to +75°C (-40°F to 167°F) high-performance mode Storage range: -40°C to +85°C (-40°F to 185°F)
Relative Humidity	Operating: 5% to 95% non-condensing
Shock/Vibration	Non-operational shock: 500 g's, Non-operational vibration: 20 g's
Warranty	2-year limited warranty
Included Software	Windows™ 98/NT/2000/XP-based DeviceInstaller configuration software and Windows™-based Comm Port Redirector
EMI Compliance	Radiated & conducted emissions - complies with Class B limits of EN 55022:1998 Direct & Indirect ESD - complies with EN55024:1998 RF Electromagnetic Field Immunity - complies with EN55024:1998 Electrical Fast Transient/Burst Immunity - complies with EN55024:1998 Power Frequency Magnetic Field Immunity - complies with EN55024:1998 RF Common Mode Conducted Susceptibility - complies with EN55024:1998

### DC Characteristics for Serial, PIO, and Power Interface

Symbol	Parameter	Min	Nominal	Max	Units
V <sub>CC</sub>	Supply voltage (typical 3.3) (+/-5%)	3.14	3.3	3.46	V
V <sub>IL</sub>	Low Level Input Voltage	0		0.8	V
V <sub>IH</sub>	High Level Input Voltage	2.0		5.5	V
V <sub>OL</sub>	Low Level Output Voltage			0.4	V
V <sub>OH</sub>	High Level Output Voltage	2.4			V
I <sub>I</sub>	Input Leakage Current			1	µA
I <sub>CC</sub>	Supply Current (idle)@ 48 MHz		119		mA
I <sub>CC</sub>	Supply Current (10BASE-T activity)@ 48 MHz		224		mA
I <sub>CC</sub>	Supply Current (10BASE-T activity)@ 88 MHz		267		mA
I <sub>CC</sub>	Supply Current (100BASE-T activity)@ 48 MHz		190		mA
I <sub>CC</sub>	Supply Current (100BASE-T activity)@ 88 MHz		233		mA

With the purchase of XPort, the OEM agrees to an OEM firmware license agreement that grants the OEM a non-exclusive, royalty-free firmware license to use and distribute the binary firmware image provided, only to the extent necessary to use the XPort hardware.

## Development Kit

### Introduction

An XPort development kit is available to provide a simple, quick, and cost-effective way to evaluate the XPort. Use the development kit to integrate the XPort to your product design, and give your newly networked product a test drive.

### Features of the Development Kit

- Complete, ready to use XPort and supporting evaluation board
- +5VDC Universal Power Supply
- RS-232 cable, DB9M/F
- CAT5e UTP RJ45M/M Ethernet cable
- Serial adapter, 25-pin to 9-pin
- XPort CD containing a configuration utility, DeviceInstaller, Comm Port Redirector, sample code and complete user manual in PDF



### Ordering Information

XPort-XE	XP1001000-03	Standard XPort	Min. order: 50 units
XPort-SE	XP1002000-03	Standard XPort with 256-bit AES encryption	Min. order: 50 units
XPort-SE SMPL	XP100200S-03	XPort Sample with encryption	One XPort enclosed
Xport Dev. Kit	XP100200K-03	XPort Development Kit with encryption	

### Block Diagram

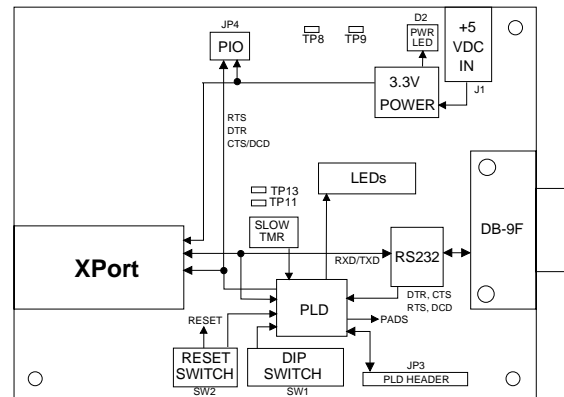

### Features of the Evaluation Board

The XPort evaluation board includes an XPort integrated with the following features:

- RS-232 (DCE) serial interface
- DIP switch configuration
- LED indication for power, RS-232 transmit / receive and PIO status
- Reset circuit with pushbutton
- Header connector for the PIO signals CP1, CP2, and CP3
- Test points to monitor the XPort's serial interface signals
- Timer



For details contact your local Lantronix representative or Lantronix directly:

**Asia Pacific Region** via e-mail at [AsiaPacific\\_sales@lantronix.com](mailto:AsiaPacific_sales@lantronix.com)

**Europe** via e-mail at [eu\\_sales@lantronix.com](mailto:eu_sales@lantronix.com)

**Japan** via e-mail at [japan\\_sales@lantronix.com](mailto:japan_sales@lantronix.com)

**United States** via e-mail at [sales@lantronix.com](mailto:sales@lantronix.com) or call OEM sales support at 800-526-8764

©2004 Lantronix, Inc. All rights reserved. Lantronix, XPort, with its patent-pending technology, and DSTni are trademarks of Lantronix. All other trademarks are the property of their respective owners. Specifications subject to change without notice. All rights reserved.