

# NOTE 10.

## MCP3202 12 Bit A/D Conversion

The CUBLOC has a 10 bit A/D converter. Without a separate chip, you can get up to 10 bits of A/D conversion. But for greater resolution, meaning greater precision, you can use a chip like the MCP3202. MCP3202 is a 12 bit A/D converter that supports SPI protocol.

Here we will show you how to implement this 12 bit A/D converter into your project.

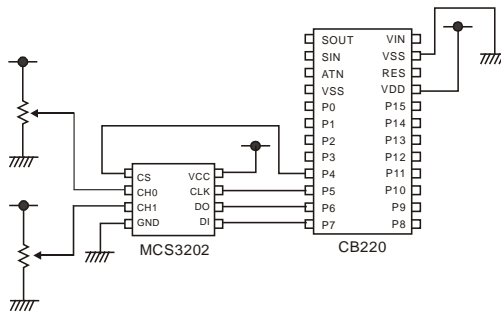

Pin	Function	I/O Direction	Explanation
CS	Chip Select	Input	Low for data communication
CLK	Clock	Input	Clock signal
DI	Data Input	Input	Data input from MCP3202
DO	Data Output	Output	Data output from MCP3202

<Filename: mcp3202.cul>

```

Const Device = CB280
Const iodi = 7
Const iodo = 6
Const ioclk = 5
Const iocs = 4
Dim I As Byte
Dim ad As Integer
Do
    Low iocs

```

```
i = &b1011 'Channel 0
'i = &h1111 'Channel 1
Shiftout ioclk,iodi,0,i,4
ad = Shiftin(ioclk,iodo,3,12)
High iocs
Debug Dec ad,cr
Delay 100

Loop
```

The MCP3202 will convert voltage coming into CH0 and CH1 ports to a data value and retain it. The user can simply use SPI communication to read the value that the MCP3202 has converted.

The voltage inputted to the MCP320 CH0 and CH1 pins must not be greater than the voltage supplied to the MCP3202. The result of A/D conversion is displayed to the DEBUG window.

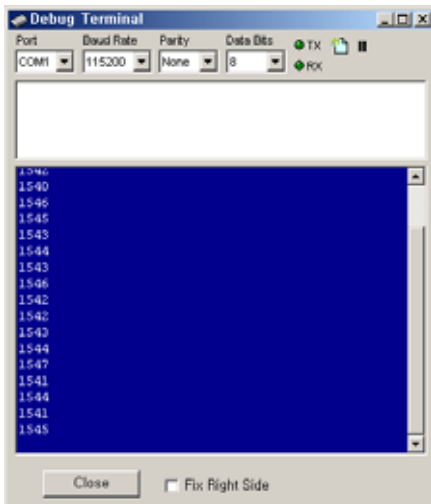

<END>